

H231



COMPACT STRUCTURE

- Finishes : **White**
- Shape of Basin : **Rectangular**
- Body Material : **Premium Vitreous China**
- Installation : **Easy wall-mounted / wall-hung**
- Overflow Hole : **Integrated overflow system**
- Configuration : **Wash basin with optional integrated pedestal/shroud profile**

DIMENSIONS & TECHNICAL SPECIFICATIONS

- Width (Left to Right) : **505 mm**
- Depth (Front to Back) : **420 mm**
- Height : **390 mm**
- Net Weight : **20 kg**

TECHNICAL SPECIFICATIONS

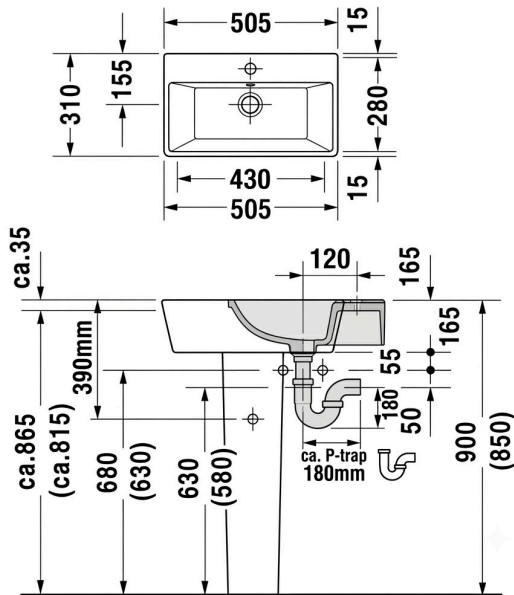

PRODUCT CONFIGURATION OPTIONS

- Monobloc mixer tap-hole compatibility (Center punched)
- Compatible with premium chrome bottle traps or concealed waste pipes
- Heavy-duty fixing bolt kit options for reinforced wall structures



The Inspirione tap series sets the new benchmark for public restroom solutions. With the first actuation of the Smart Tap, soap is released and afterwards a smooth water flow for a clean, hygiene, and efficient handwashing.

The information contained in this document is subject to change without prior notice.